

STP 系列离心泵

SERIES CENTRIFUGAL PUMPS



STP series stainless steel single stage centrifugal pumps, it is designed for industrial use which is suitable for drinkable water, wine, medicine industry and so on. The hydraulic characteristics with middle head and large capacity.

STP 系列为不锈钢单级离心电泵。为工业用而设计，适用输送纯净水、饮用水、酒业、药业等场合。其水力特性为中扬程大流量。

WORKING CONDITIONS

- Max Temperature of Fluid up to +60°C
- Max Pressure 10bar
- Max Ambient Temperature up to 40°C

工作条件：

- 最高流体温度为60°C
- 最大可承受的压力10bar
- 最高环境温度40°C

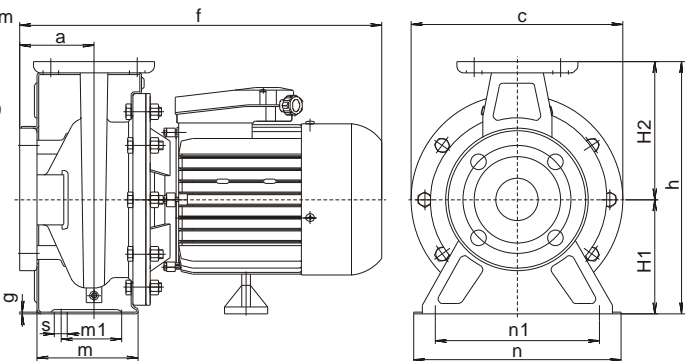
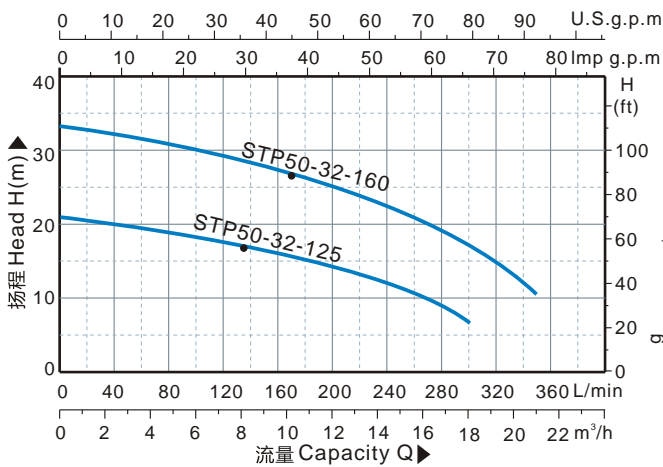

技术参数 TECHNICAL DATA AT 220~240V/50Hz

型号 TYPE	输入功率 Input Power		电流 Current (A)	最大流量 Q _{max} (l/min)	最高扬程 H _{max} (m)	最大吸程 S.Head (M)	转速 Speed (r/min)	总扬程 Total head(m)	流量 Capacity(l/min)										
	KW	HP							0	40	80	120	160	200	240	280	320		
STP50-32-125	1.5	2	8.8	300	21	9	2850	21	20	18	17	15	14	12	8				
STP50-32-160	2.2	3	12.8	350	33	9		33	32	30	29	27	25	22	19	15			

Note: 110V/60Hz, 115V/60Hz, 127V/60Hz, 110/220V/60Hz, 380V/50Hzets. Models are available on request
备注: 可以按要求生产110V/60Hz, 115V/60Hz, 127V/60Hz, 110/220V/60Hz等电压频率

安装尺寸 DIMENSIONS

型号 TYPE	外形尺寸 Dimensions(mm)													包装尺寸 Packing Size (mm)			毛重 G.W KG	包装数量 Packing QTY 20'柜(Cont)		
	进口 DNA		出口 DNM		a	f	h	h1	h2	m	m1	n	n1	g	s	L			W	H
	inch	mm	inch	mm																
STP50-32-125	2"	50	2"	50	86	420	292	132	160	117	70	240	190	2	15	450	270	315	23	700
STP50-32-160	2"	50	2"	50	86	420	292	132	160	117	70	240	190	2	15	450	270	315	25	700