

SCM 系列离心泵

SERIES CENTRIFUGAL PUMPS



SCM series are single stage centrifugal pumps, can be used to transfer clean water or other similar water in physical and chemical properties. It is suitable for industrial use and urban water supply, pressure boosting for high buildings and fire system, garden irrigation, long-distance water transfer, heating ventilation and air controlling, circulation and pressure boosting for cold and hot water, and supporting equipment etc.

SCM 系列为单级离心水泵，主要用于输送清水和其他与水性质类似的液体，适用于工业和城市供水、高层建筑增压、消防系统、园林灌溉、长途水输送、暖通和空气调节、冷热水循环增压和配套设施等。

WORKING CONDITIONS

- Max Temperature of Fluid up to +60°C
- Max Pressure 10bar
- Max Ambient Temperature up to 40°C

工作条件：

- 最高流体温度为60°C
- 最大可承受的压力10bar
- 最高环境温度40°C

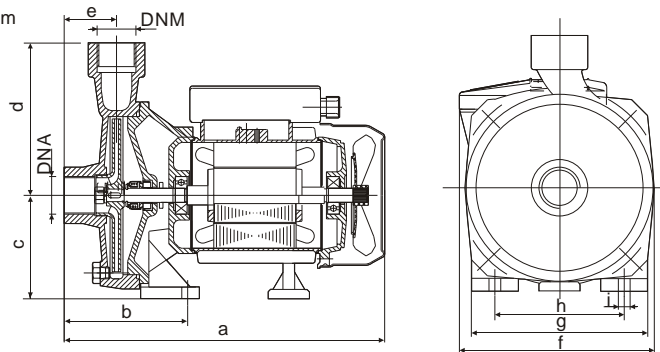
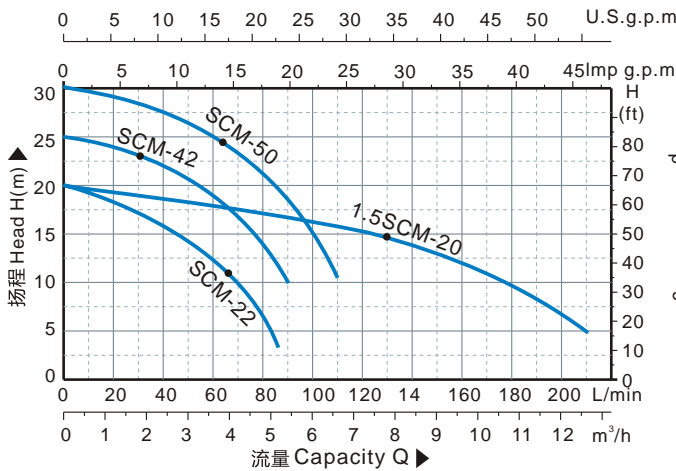

技术参数 TECHNICAL DATA AT 220~240V/50Hz

型号 TYPE	输入功率 Input Power		电流 Current (A)	最大流量 Q _{max} (l/min)	最高扬程 H _{max} (m)	最大吸程 S.Head (M)	转速 Speed (r/min)	流量 Capacity(l/min)											
	KW	HP						0	20	40	60	80	100	120	140	180			
SCM-22	0.37	1/2	2.5	85	20	9	2850	总扬程 Total head(m)	20	20	18	16	12.5	6					
SCM-42	0.55	3/4	3.6	90	25	9			25	25	24	22	18.5	13					
SCM-50	0.75	1	4.8	110	30	9			30	30	29	27.5	25	21	15				
1.5SCM-20	0.75	1	4.8	210	20	9			20	19	18	17	16.5	16	15	13	9		

Note: 110V/60Hz, 115V/60Hz, 127V/60Hz, 110/220V/60Hz, 380V/50Hz etc. Models are available on request
备注: 可以按要求生产110V/60Hz, 115V/60Hz, 127V/60Hz, 110/220V/60Hz等电压频率

安装尺寸 DIMENSIONS

型号 TYPE	外形尺寸 Dimensions(mm)												包装尺寸 Packing Size (mm)			毛重 G.W KG	包装数量 Packing QTY 20'柜(Cont)	
	进口 DNA		出口 DNM		a	b	c	d	e	f	g	h	i	L	W			H
	inch	mm	inch	mm														
SCM-22	1"	25	1"	25	270	100	83	114	43	156	150	110	10	310	170	230	8.5	2100
SCM-42	1"	25	1"	25	303	108	98	144	45	165	181	140	10	340	210	260	12.5	1600
SCM-50	1"	25	1"	25	319	108	98	144	45	185	181	140	10	340	210	260	13.6	1500
1.5SCM-20	1.5"	40	1.5"	40	313	53	97	125	45	170	150	142	10	350	210	265	14	1400