

# CM 系列离心泵

## SERIES CENTRIFUGAL PUMPS



CM series are single stage centrifugal pumps, can be used to transfer clean water or other similar water in physical and chemical properties. It is suitable for industrial use and urban water supply, pressure boosting for high buildings and fire system, garden irrigation, long-distance water transfer, heating ventilation and air controlling, circulation and pressure boosting for cold and hot water, and supporting equipment etc.

CM 系列为单级离心电泵，主要用于输送清水和其他与水性质类似的液体，适用于工业和城市供水、高层建筑增压、消防系统、园林灌溉、长途水输送、暖通和空气调节、冷热水循环增压和配套设施等。

### WORKING CONDITIONS

- Max Temperature of Fluid up to +60°C
- Max Pressure 10bar
- Max Ambient Temperature up to 40°C

### 工作条件：

- 最高流体温度为60°C
- 最大可承受的压力10bar
- 最高环境温度40°C

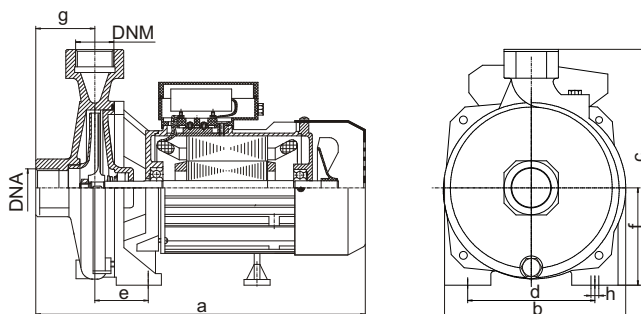
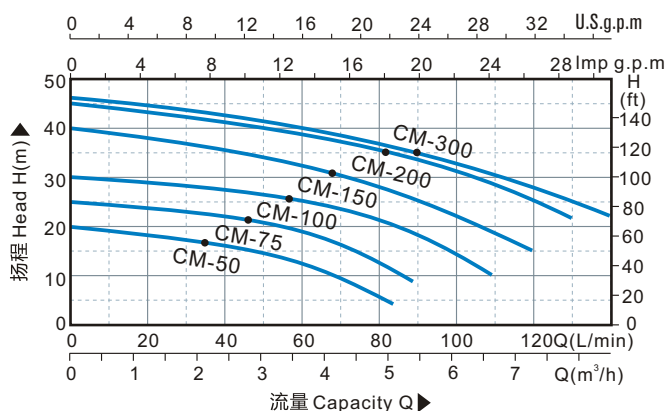

### 技术参数 TECHNICAL DATA AT 220~240V/50Hz

型号 TYPE	输入功率 Input Power		电流 Current (A)	最大流量 Q <sub>max</sub> (l/min)	最高扬程 H <sub>max</sub> (m)	最大吸程 S.Head (M)	转速 Speed (r/min)	流量 Capacity(l/min)										
	KW	HP						0	20	40	60	80	100	120	130			
CM-50	0.37	1/2	2.5	85	20	9	2850	总扬程 Total head(m)	20	18	16	12.5	6					
CM-75	0.55	3/4	3.6	90	25	9			25	24	22	18.5	13					
CM-100	0.75	1	4.8	110	30	9			30	29	27.5	25	21	15				
CM-150	1.1	1.5	6.6	120	40	9			40	37.5	35	32	28	22	15			
CM-200	1.5	2	8.8	130	45	9			45	43	41	38	36	32.5	27.5	21		
CM-300	2.2	3	11	140	46	9			46	44	42	40	37	33	28	22		

Note: 110V/60Hz, 115V/60Hz, 127V/60Hz, 110/220V/60Hz, 380V/50Hz etc. Models are available on request  
备注：可以按要求生产110V/60Hz, 115V/60Hz, 127V/60Hz, 110/220V/60Hz等电压频率

### 安装尺寸 DIMENSIONS

型号 TYPE	外形尺寸 Dimensions(mm)												包装尺寸 Packing Size (mm)			毛重 G.W	包装数量 Packing QTY. 20'柜(Cont)
	进口 DNA		出口 DNM		a	b	c	d	e	f	g	h	L	W	H		
	inch	mm	inch	mm													
CM-50	1"	25	1"	25	270	157	203	110	95	84	44	10	260	175	235	8.5	2300
CM-75	1"	25	1"	25	320	185	232	140	102	95	46	10	310	210	260	12	1600
CM-100	1"	25	1"	25	320	185	232	140	102	95	46	10	310	210	260	13.5	1450
CM-150	1.25"	30	1.25"	30	360	217	290	190	120	117	53	10	420	255	335	20	1000
CM-200	1.25"	30	1.25"	30	360	217	290	190	120	117	53	10	420	255	335	22	900
CM-300	1.25"	30	1.25"	30	360	217	290	190	120	117	53	10	420	255	335	23.5	850